

# IP66-Rated Power Supply Solutions

## ABSOPULSE D4 Series, 500W Output Power

ABSOPULSE Electronics offers a broad selection of heavy-duty power conversion products packaged in rugged, waterproof die cast aluminum IP66-rated enclosures. The enclosures provide protection from the water from powerful jets, fog, sand, metal dust, dust, oil, insects and other contaminants.

### Output power

The D4 size IP66 enclosure accommodates any DC or AC input power converter, with a typical power rating of 500W. Higher ratings are possible, depending on input/output combination.

### Typical designs

ABSOPULSE designs available in the D4 size enclosures include the BAP 319-D4, BAP 319R-D4, DCW 500-D4, PFC 319-4 and RWY 500-D4.

### Cooling

Cooling is by internal conduction to the walls of the IP66 enclosure and by baseplate to an external chassis or cabinet wall, with additional convection via the outside surface. This enables operation within a -25°C to +55°C temperature range for full specification. Installation on a heat-sinking surface significantly improves cooling.

### Ruggedizing

The internal boards are ruggedized and conformal coated for immunity to shock and vibration. Encapsulation of the internal module is available for increased protection from high levels of shock and vibration.

### Connectors

Options available include sealed circular connectors, cable glands or custom.

### Mounting

By mounting flanges

### Weight

D4: 5.8 kg (12.8 lb.)  
Weight excludes internal module.

**Enhancements to specifications are also available.**



**D4G version (IP66)**  
**Sealed cable glands**

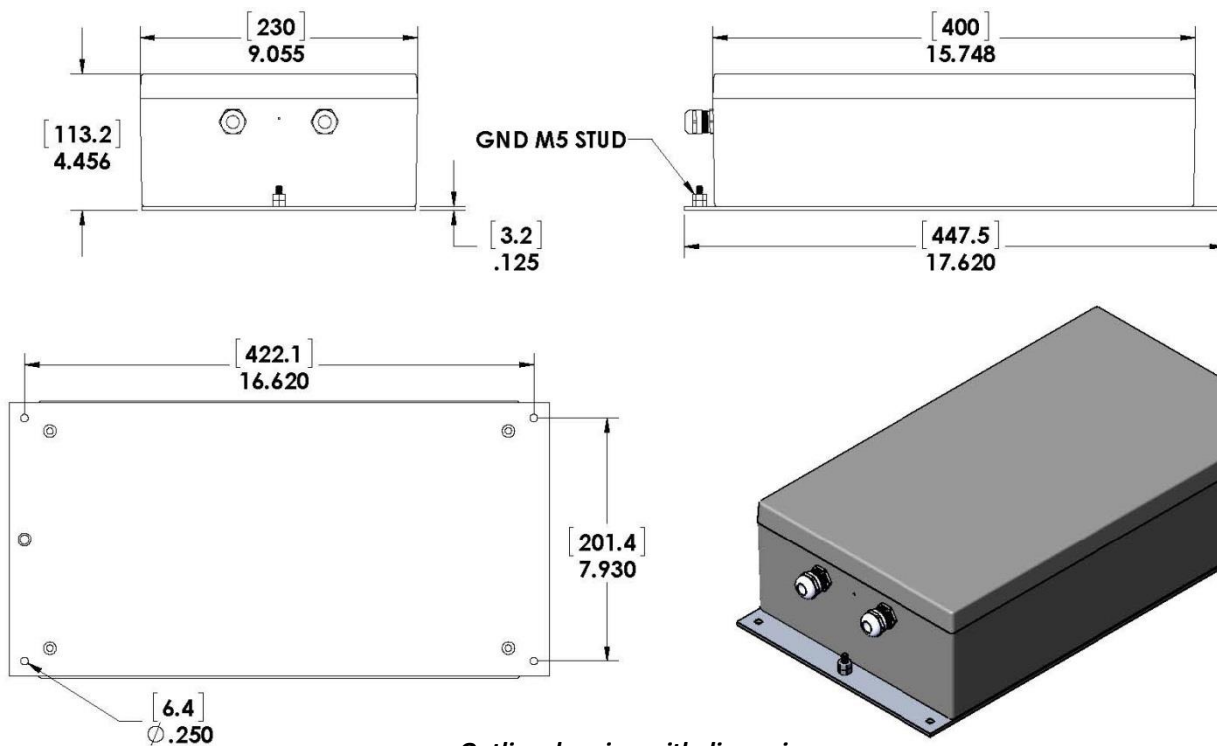

**Outline drawing with dimensions**

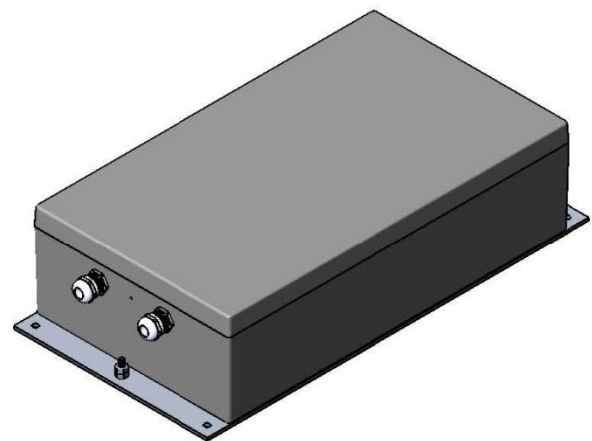

*Designer and manufacturer of rugged power conversion solutions for industrial and railway applications. Our product line includes DC-DC converters, AC-DC power supplies and battery chargers, DC-AC sine wave inverters, AC-AC frequency converters, UPS systems, complete power systems in 19" and 23" racks. Custom or standard. ABSOPULSE is a BABT approved facility. Established in 1982.*



**ABSOPULSE ELECTRONICS LTD**  
110 Walgreen Road, Ottawa, Ontario | K0A 1L0 | CANADA  
T: +1-613-836-3511 | F: +1-613-836-7488  
<https://absopulse.com/contact> | <https://www.absopulse.com>