

APPROVED
By Document2 at 10:44 am, Mar 12, 2015

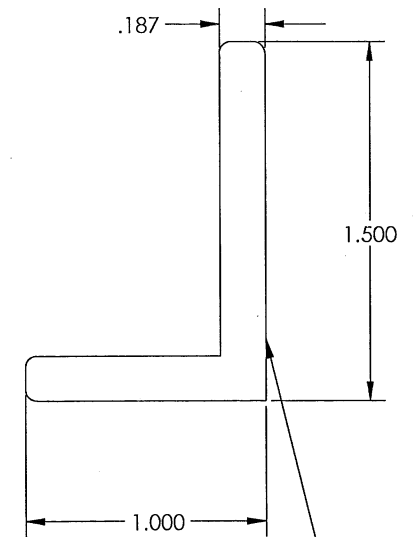
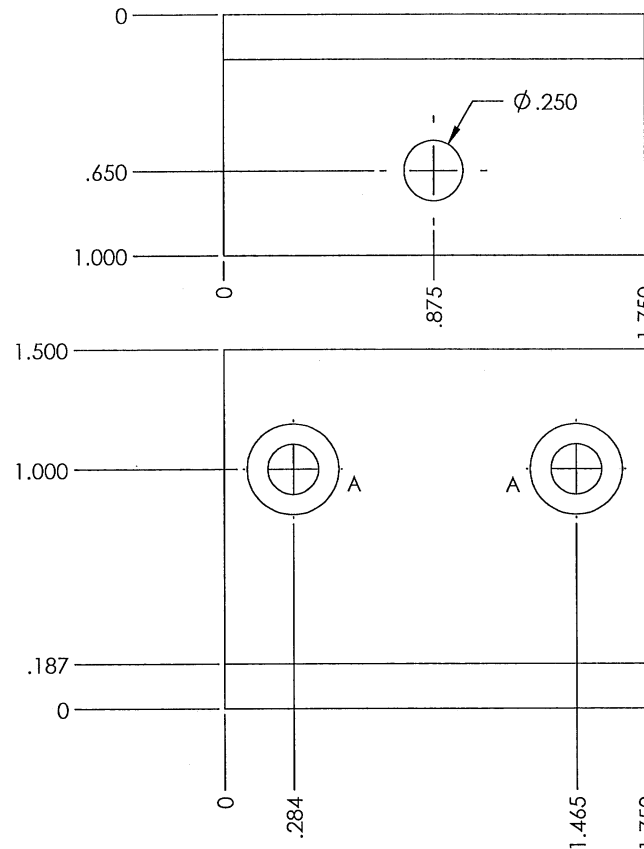
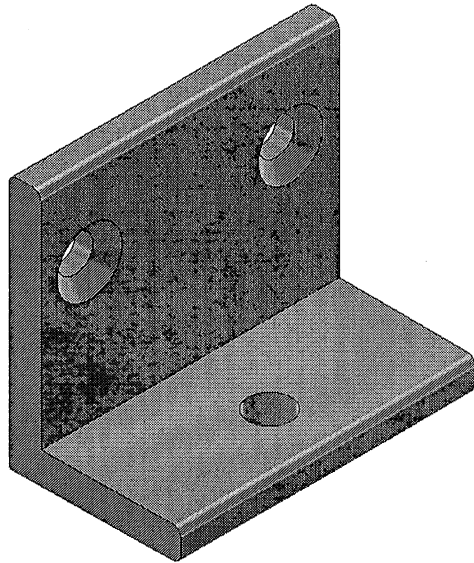

PART NO. DWG. NO.
STAMPED ON THIS SURFACE

MATERIAL: ALUMINIUM 6061-T6
EXTRUSION 1"X1.5"X.187"

FINISH: CLEAR IRIDITE

HOLES:
A 0.210" DIA & C.S. 90° X 0.380" DIA QTY:2
C.S. ON NEAR SIDE

WEIGHT:32g

REV	DESCRIPTION:	DATE	MUST BE RoHS COMPLIANT	DIMENSIONS ARE IN INCHES TOLERANCES ON DECIMALS: XXX ± 0.008" XX ± 0.012"	THIS DOCUMENT IS THE PROPERTY OF ABSOPULSE ELECTRONICS LTD. ITS CONTENTS ARE PROPRIETARY AND MAY NEITHER BE COPIED, REPRODUCED NOR ITS CONTENTS DISCLOSED TO OTHERS WITHOUT PRIOR WRITTEN AGREEMENT FROM ABSOPULSE ELECTRONICS LTD.	Title: L-BRACKET			ABSOPULSE	
A	NEW ISSUE	05/03/15				Part of: U7712	Date: MAR.05/2015			
			EDGES & HOLES DEBURRED SURFACES FREE OF SCRATCHES	ANGLES: ± 2° FRACTIONS: ± 1/64" UNLESS OTHERWISE STATED	Drawn by: J.X.	Checked by:	Approved by:	Revision: 1	Drawing No: MDR 998 752-001A	